



YANMAR

SV100-7

COMPACT EQUIPMENT ULTRA-TIGHT TAIL MINI EXCAVATOR



**Some features shown may be optional or not available.*

Top mobility and raw power in the 10-ton class.

The SV100-7 might surprise you. Yes, you know its 72-HP Tier 4 Final YANMAR diesel engine provides the power, digging force and lifting capacity you need to take on the tough jobs. But Yanmar also builds the SV100-7 with an ultra-tight turning radius to navigate tight, confined jobsites that provide so much trouble for bigger excavators. It doesn't stop there. The SV100-7 comes standard with 2-Pump Load Sensing hydraulic system, directing hydraulic flow where it's most needed and allowing for higher speeds and maximum fuel efficiency. Plus, you can work in more comfort with the spacious operator area, 7-inch color display, improved visibility and more.

QUICK SPECS

Weight	Horsepower	Max Dig Depth
21,671 lbs	72 hp	14' 11"

INNOVATIVE FEATURES



Unbeatable Cab Comfort

Work in comfort with a quieter and more spacious operator area outfitted with ergonomic controls and a 7-inch color display. Keep an eye on your surroundings with increased visibility from more glass area and standard side and rear cameras.



Efficient 2PLS Hydraulics

Take advantage of fuel savings with no sacrifice to power. Yanmar outfits the SV100-7 with 2PLS hydraulics for a 13% reduction in fuel consumption combined with an extraordinary boost in machine performance, productivity and travel speeds.



Convenient Maintenance Access

Complete maintenance work and refueling quickly and efficiently with an engine bay designed for maximum accessibility. The open cabin hoods put the generator, valves, radiator, oil-water separator and more right at your fingertips.

Dimensions - SV100-7

- A** 14 ft. 11 in. (4,570 mm)
- B** 15 ft. 10 in. (4,830 mm)
- C** 13 ft. 9 in. (4,210 mm)
- D** 24 ft. 8 in. (7,530 mm)
- E** 24 ft. 1 in. (7,360 mm)
- F** 21 ft. 1 in. (6,440 mm)
- G** 16 ft. 1 in. (4,910 mm)
- H** 6 ft. 8 in. (2,050 mm)
- I** 10 ft. (3,060 mm)
- J** 7 ft. 3 in. (2,210 mm)
- K** 1 ft. 7 in. (500 mm)
- L** 1 ft. 7 in. (500 mm)
- M** 8 ft. 9 in. (2,670 mm)
- N** 9 ft. (2,750 mm)
- O** 5 ft. 6 in. (1,690 mm)
- P** 16 ft. 8 in. (5,090 mm)
- Q** 25 ft. 3 in. (7,710 mm)
- R** 7 ft. 7 in. (2,320 mm)
- S** 6 ft. 1 in. (1,870 mm)
- T** 1 ft. 4 in. (475 mm)
- U** 1 ft. 4 in. (410 mm)
- V** 2 ft. 7 in. (795 mm)
- W** 1 ft. 11 in. (595 mm)
- X** 5.5 in. (135 mm)

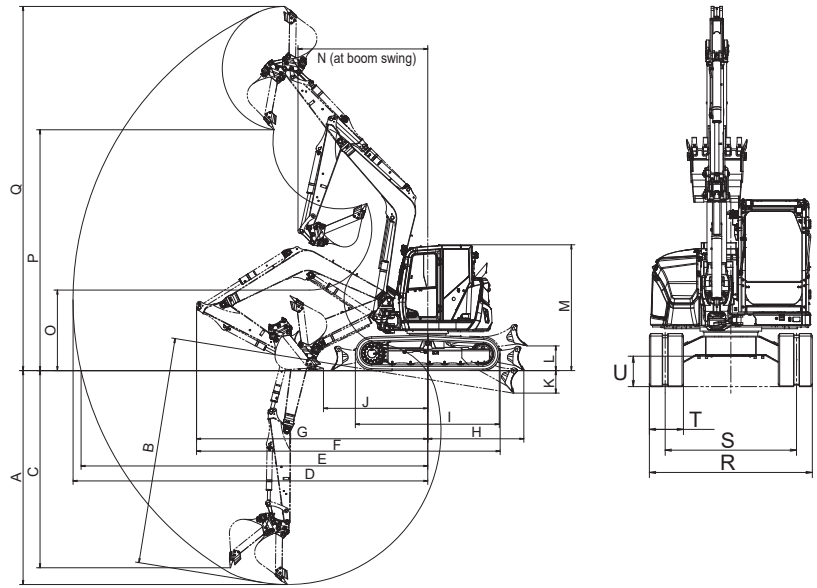
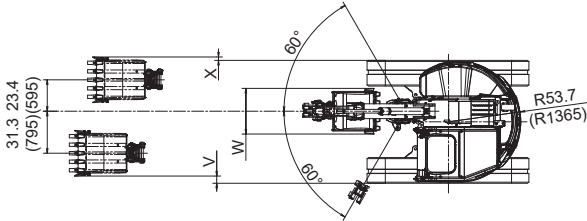

Specifications

Model		SV100-7	
Type		Cab. Rubber Track	Cab. Steel Track
Operating Weight		lbs (t)	
		21,671 (9.8)	21,914 (9.9)
Engine	Type	Vertical water-cooled 4-cylinder diesel	
	Model	4TNV98CT-VBV2	
	Output	HP (kW)/rpm 72 (53.7) / 2100	
Performance	Max Digging Force, Bucket / Arm	lbs (kN) 12,027 (53.5) / 9,487 (42.2)	
	Traveling Speed, High / Low	MPH (km / h) 2.7 (4.3) / 1.3 (2.1) 2.5 (4.0) / 1.2 (2.0)	
	Swing Speed	RPM 9.0	
	Boom Swing Angle, (L / R)	degrees 60° / 60°	
	Gradability	degrees 25°	
Ground Contact Pressure		PSI (kPa)	
		5.5 (38.1)	5.7 (39.1)
Hydraulic System	Pump Capacity	GPM (L / min) 36.4 (137.8) x 2 (variable) · 5.5 (21) x 1 (gear)	
	Main Relief Set Pressure	PSI (MPa) 3988 (27.5) x 2 · 493 (3.4) x 1	
Blade Dimensions	Width x Height	ft-in (mm) 7'7" (2,320) x 1'8" (520)	
	Working Area of Blade (Upper/Lower)	ft-in (mm) 1'7" (485) / 1'7" (485)	
Fuel tank capacity		Gals (L) 30.9 (117)	

Standard Equipment

- Double Lock Quick Coupler
- Blade with Float
- Boom Swing Function
- Rubber Tracks
- Flow Selector Valve on AUX1 Circuit
- Antenna and Pre-wired for Radio
- Right Side and Rear View Cameras
- 4-Way Multi Pattern Control
- LCD Passcode Function
- Windshield Washer
- Air Conditioner
- Defroster
- Joystick Pilot Controls
- Suspension and Reclining Seat
- Seat Belt
- Proportional Auxiliary Controls
- Automatic 2-Speed Travel
- Auto Decel Switch
- Eco Mode Switch
- Traveling Alarm
- Floor Mats

Please note that the standard equipment may vary from this list. Consult your Yanmar dealer for confirmation.

Hydraulic PTO

Model		SV100-7	
Output		GPM (L / min)	
Specification		AUX1 2100RPM	AUX2 2100RPM
Combined Flow, Double Actions		26.4 (100)	18.5 (70)

Lifting Capacity

LIFT POINT HEIGHT h:in (mm)	r:REACH in (mm)											
	RATED LIFT CAPACITY OVER END BLADE DOWN				RATED LIFT CAPACITY OVER END BLADE UP				RATED LIFT CAPACITY OVER SIDE BLADE DOWN			
	lbs (kg)				lbs (kg)				lbs (kg)			
	MAX	16'5" (5,000)	13'1" (4,000)	9'10" (3,000)	MAX	16'5" (5,000)	13'1" (4,000)	9'10" (3,000)	MAX	16'5" (5,000)	13'1" (4,000)	9'10" (3,000)
196.9 (5,000)	4,233 (1,920)		3,968 (1,800)		4,145 (1,880)		3,924 (1,780)		4,189 (1,900)		3,880 (1,760)	
157.5 (4,000)	4,123 (1,870)	4,034 (1,830)	4,123 (1,870)		3,373 (1,530)	4,056 (1,840)	4,123 (1,870)		2,954 (1,340)	3,990 (1,810)	4,056 (1,840)	
118.1 (3,000)	4,145 (1,880)	4,343 (1,970)	4,894 (2,220)	5,997 (2,720)	3,042 (1,380)	4,299 (1,950)	4,872 (2,210)	5,842 (2,650)	2,579 (1,170)	3,395 (1,540)	4,828 (2,190)	5,842 (2,650)
78.7 (2,000)	4,145 (1,880)	4,872 (2,210)	5,820 (2,640)	8,400 (3,810)	2,800 (1,270)	3,748 (1,700)	5,776 (2,620)	8,444 (3,830)	2,403 (1,090)	3,263 (1,480)	4,586 (2,080)	8,444 (3,830)
39.4 (1,000)	4,321 (1,960)	5,269 (2,390)	6,967 (3,160)	9,788 (4,440)	2,756 (1,250)	3,638 (1,650)	5,159 (2,340)	7,606 (3,450)	2,359 (1,070)	3,153 (1,430)	4,299 (1,950)	7,606 (3,450)
Ground (0)	4,387 (1,990)	5,578 (2,530)	7,231 (3,280)	10,163 (4,610)	2,800 (1,270)	3,571 (1,620)	4,938 (2,240)	7,341 (3,330)	2,425 (1,100)	3,064 (1,390)	4,145 (1,880)	7,341 (3,330)
-39.4 (-1,000)	4,409 (2,000)	5,225 (2,370)	6,967 (3,160)	9,546 (4,330)	3,108 (1,410)	3,527 (1,600)	4,828 (2,190)	7,319 (3,320)	2,668 (1,210)	3,042 (1,380)	4,079 (1,850)	7,319 (3,320)
-78.7 (-2,000)	4,387 (1,990)		6,041 (2,740)	8,201 (3,720)	3,770 (1,710)		4,938 (2,240)	8,289 (3,260)	3,263 (1,480)		4,123 (1,870)	8,289 (3,260)

Find more information on the SV100-7 at YanmarCE.com.