

COMPACT WHEEL LOADER



Specifications

Operating weight	10,802 lbs (4,900 kg)
Engine power	62 HP (46.2 kW)
Bucket capacity	1.05-1.57 yd ³ (0.8-1.2 m ³)
Tipping load, straight	8,311 lbs (3,770 kg)
Tipping load, articulated	7,341 lbs (3,330 kg)
Drawbar pull	9441.98 lbs (L) 9666.78 lbs (H)

Features

- ▶ Transverse-mounted diesel engine, high performance, minimized fuel consumption, low emissions
- ▶ Hydrostatic travel drive, high traction power, infinitely variable speed control by driving automatics, optimum driving performance in all ground conditions, wear-free braking
- ▶ Powerful hydraulics, high lifting and breakout forces
- ▶ Excellent parallel kinematics for synchronized parallel operation of bucket and forklift attachment over the entire lifting height
- ▶ Ease of operation, hydraulic pilot control, multi-function joystick for intuitive control
- ▶ Ease of serviceability, long maintenance intervals

SPECIFICATIONS

OPERATING DATA, STANDARD EQUIPMENT

Operating weight (SAE J 1197)	10,802 lbs (4,900 kg)
Tipping load, straight at full reach (ISO 14397-1)	8,311 lbs (3,770 kg)
Tipping load, articulated at full reach (ISO 14397-1)	7,341 lbs (3,330 kg)
Total length, bucket on ground	16' 6" (5,060 mm)
Total width	6' 1" (1,850 mm)
Turning radius at outside bucket edge	13' 8" (4,160 mm)
Wheelbase	6' 9" (2,100 mm) 8'
Total height (top of cab)	8' 7" (2,640 mm)

ENGINE

Manufacturer, model	YANMAR 4TNV98C	
Type	Diesel engine with intercooler, exhaust-gas optimised, EPA Tier 4 Final / EC stage 5	
Combustion	4-stroke cycle, Common Rail injection	
Number of cylinders	4 in line	
Displacement	3.3 Liter	
Net power rating at 2,200 rpm (SAE J 1349)	62 hp (46.2 kW)	
Max. torque	173 lb ft (235 Nm) @ 1,430 rpm	
Cooling system	Water	

ELECTRICAL SYSTEM

Nominal voltage	12 V
Battery	12 V / 100 Ah
Generator	14 V / 95 A
Starter	12 V / 3.5 hp (2.6 kW)
Cold-starting aid	Glow plugs

Lighting system in compliance with US/ISO standards, H7 headlamps.

POWER TRANSMISSION

Hydrostatic drive, closed circuit, independent from loader hydraulics. Perfected driving automatics, automatic optimisation and adjustment of drawbar pull and speed. Hydraulic motor power shift providing two speed ranges. Infinitely variable speed control forward and reverse. 4-wheel drive from reduction gear on rear axle via cardan shaft to front axle. Inching pedal for sensitive driving and stopping at high rpm.

4 speeds:	
Standard version	0 mph – 12.4 mph
S version	0 mph – 22.4 mph

AXLES

Rigid front axle with 35% limited slip differential. Oscillating rear axle with 35% limited slip differential. Center-mounted disc brake.

TIRES

Standard	405/70 R 18 SPT 9 Dunlop
----------	--------------------------

BRAKES

Service brake:	Hydraulically actuated center-mounted disc brake, acting on all 4 wheels via 4-wheel drive
Auxiliary brake:	Hydrostatic drive provides dynamic braking
Parking brake:	Mechanically actuated center-mounted disc brake on front axle

STEERING

Articulated, 1 steering cylinder with final positioning damping on both sides, fully hydraulic through Load-Sensing priority valve, quick and easy steering even at engine idle-running speed.

Total steering angle	80 deg.
----------------------	---------

FLUID CAPACITIES

Fuel tank	20 gal (75 l)
Hydraulic system (incl. tank)	15 gal (55 l)



HYDRAULIC SYSTEM

Max. pump capacity	17 gpm (65 l/min)
Max. working pressure	3,634 psi (250 bar)

Control unit: Proportional hydraulic valve with 3 control circuits, supplying work functions "Lift/Lower", "Dump/Tilt-back with high-speed control" and "3rd control circuit (1st additional control circuit)". Simultaneous, independent control of all movements.

Hydraulic cylinders: 1 lifting cylinder, 1 tilt cylinder, all dual-action

The thermostatically controlled oil circuit ensures that the oil temperature is promptly reached and avoids overheating. Return filter installed in hydraulic tank allows for eco-friendly replacement of filter elements.

Fingertip control for 3rd control circuit, electro-proportional, oil flow limitation via machine function display, continuous operation. Installation on loader frame incl. couplings.

Hydraulically switchable float position by overdriving the pressure point "Lower" on the joystick, electrically switchable continuous operation function.

Single, four-way control lever (joystick) with integrated direction-of-travel switch and switch for additional control circuit.

LOADER FRAME

Loader installation featuring true parallel linkage and hydraulic quick coupler	
General-purpose bucket (SAE J 742)	1.05 yd ³ (0.80 m ³)
Lift capacity at ground level (SAE J 732)	10,800 lbs (48,000 N)
Breakout force at bucket edge (SAE J 732)	10,328 lbs (45,900 N)

FORK LIFT ATTACHMENT

Operating load (SAE J 1197) over the total lift and steering range	2,945 lbs (1,335* kg)
Operating load in transport position, above ground level, total steering range	5,512 lbs (2,500* kg)
Width of fork carrier	4' 1" (1,240 mm)
Length fork tines 4" x 1.8" (100 mm x 45 mm)	3' 6" (1,100 mm)
Stability factor	1.25
Load center from fork attachment point	22" (560 mm)

CAB

Rubber-mounted full-vision steel cab, ROPS (EN ISO 3471) and FOPS** (EN ISO 3449) certified.

Cab featuring two doors, intermittent wipers and washer (front and rear), tinted panoramic safety glass, sliding window on left-hand side, sun-blind.

Driver's seat MSG 85 (comfort version), with hydraulic cushioning, extra-high backrest, lumbar support, longitudinal and tilt adjustments, lap belt, in compliance with ISO 7096 and ISO 6683.

Cab heating with 3-speed heater fan (choice fresh air/recirculating air) and windshield defroster, front and rear.

Standard: Air conditioning. Back-up alarm for reverse travel. Battery disconnecter. Guard for fan wheel and V-belt. Immobilizer, electronic, keypad operation. 2 working floodlights, front. 2 working floodlight, rear. Rear axle weights, approx. 575 lbs (260 kg). Steering wheel with height and tilt adjustment.

Cab exterior noise level	101 dB (A)
Cab interior noise level	75 dB (A)

Noise level values measured in compliance with Directive 2000/14/EC and EN474.

*With rear axle weights

**FOPS-approved only with skylight guard (optional)

DIMENSIONS GENERAL-PURPOSE BUCKET

Capacity (SAE J 742): 1.05 yd³ (0.80 m³)
 Density of material: Max 3,000 lbs/yd³ (1.8 t/m³)

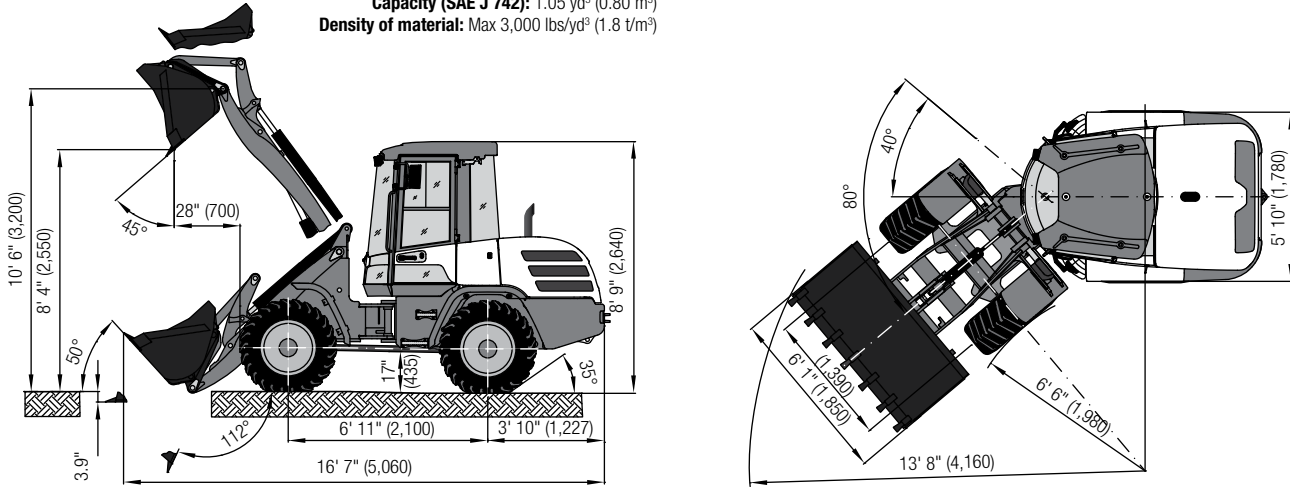

FORK LIFT ATTACHMENT

Operating load over total lift range: 2,945 lbs (1,335 kg)*
 Operating load in transport position: 5,512 lbs (2,500 kg)*
*With rear axle weights

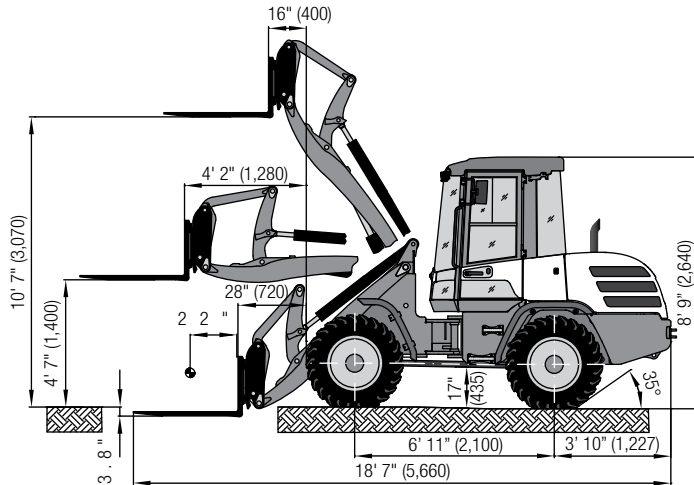

BUCKET TYPE

	Capacity	Density	Width	Dump height
General-purpose bucket, quick coupler (QC), teeth	1.05 yd ³ (0.80 m ³)	3,000 lbs/yd ³ (1.8 t/m ³)	6' 1" (1,850 mm)	8' 4" (2,550 mm)
General-purpose bucket, QC, bolt-on cutting edge	1.05 yd ³ (0.80m ³)	3,000 lbs/yd ³ (1.8 t/m ³)	6' 1" (1,850 mm)	8' 3" (2,510 mm)
Earth bucket, QC, teeth	1.18 yd ³ (0.90 m ³)	2,700 lbs/yd ³ (1.6 t/m ³)	6' 1" (1,850 mm)	8' 2" (2,485 mm)
Earth bucket, QC, bolt-on cutting edge	1.18 yd ³ (0.90m ³)	2,700 lbs/yd ³ (1.6 t/m ³)	6' 1" (1,850 mm)	8' 0" (2,445 mm)
Light-material bucket, QC, bolt-on cutting edge	1.31 yd ³ (1.00 m ³)	2,000 lbs/yd ³ (1.2 t/m ³)	6' 1" (1,850 mm)	7' 11" (2,435 mm)
Light-material bucket, QC, bolt-on cutting edge	1.57 yd ³ (1.20 m ³)	1,333 lbs/yd ³ (0.8 t/m ³)	6' 5" (1,950 mm)	7' 10" (2,395 mm)
Multi-purpose bucket, QC	.99 yd ³ (0.75 m ³)	2,700 lbs/yd ³ (1.6 t/m ³)	6' 1" (1,850 mm)	8' 3" (2,525 mm)
Side-dump bucket, QC, without teeth	.92 yd ³ (0.70 m ³)	3,000 lbs/yd ³ (1.8 t/m ³)	6' 1" (1,850 mm)	8' 3" (2,450 mm)
High-tip bucket, QC, without teeth	.92 yd ³ (0.70 m ³)	2,000 lbs/yd ³ (1.2 t/m ³)	6' 1" (1,850 mm)	11' 7" (3,540 mm)
Quarry bucket, QC	.92 yd ³ (0.70 m ³)	3,000 lbs/yd ³ (1.8 t/m ³)	6' 1" (1,850 mm)	8' 4" (2,530 mm)

EXAMPLES OF MATERIAL DENSITIES

Earth (top soil):	2,550 lbs/yd ³ (1,512 kg/m ³)	Clay (dry), clay & gravel (wet), earth with sand & gravel:	3,100 lbs/yd ³ (1,839 kg/m ³)
Earth (dry):	2,650 lbs/yd ³ (1,572 kg/m ³)	Gravel (sandy), gravel (wet):	3,700 lbs/yd ³ (2,195 kg/m ³)
Earth (moist), clay with gravel (dry):	3,000 lbs/yd ³ (1,780 kg/m ³)	Clay (natural bed), clay (wet)	3,500 lbs/yd ³ (2,077 kg/m ³)
Earth (compacted), gravel (dry):	3,000 lbs/yd ³ (1,780 kg/m ³)		

OPTIONAL EQUIPMENT

TIRES

340/80 R 18 TRI Nokian
 340/80 R 20 XMCL Michelin
 400/70 R 20 IT520 Goodyear
 Rims

FRONT ATTACHMENTS

General-purpose bucket*	1.05 yd ³ (0.80 m ³)
Earth bucket*	1.18 yd ³ (0.90 m ³)
Light-material bucket*	1.57 yd ³ (1.20 m ³)
Multi-purpose bucket*	0.99 yd ³ (0.75 m ³)
Fork lift attachment: Fork carrier ISO 2328, class 2, form B, 49" (1,240 mm) wide	
Forks: 44" (1,100 mm) long, 4" (100 mm) wide, 1.8" (45 mm) tall	
Forks: 47" (1,200 mm) long, 4" (100 mm) wide, 1.8" (45 mm) tall	
Forks: 60" (1,500 mm) long, 4" (100 mm) wide, 1.8" (45 mm) tall	
*optionally with bolt-on cutting edge	

DRIVER'S STAND

Driver's seat MSG 95 (premium version), with air-cushioning, extra-high backrest, orthopedic lumbar support, longitudinal and tilt adjustments, adjustable armrests, seat heating

HYDRAULIC SYSTEM

4 th control circuit, Fingertip control, (electro-proportional control) and installation on lift frame incl. couplings and continuous operation e.g. for attachments with 2 hydr. functions	4 th control circuit, High-Flow, 30.6 gal/min (117 l/min), 2,610 psi (180 bar), (electro-proportional control) and installation on lift frame incl. couplings
Low-temperature package fluids	Ride control system

QUICK COUPLER SYSTEMS

Quick coupler skid steer system, mechanical or hydraulic
 Quick coupler, hydraulic

CAB

FOPS-skylight guard	Rotating beacon, yellow
Right-hand door with sliding window	Radio installation kit
Outside rear-view mirror, heatable	Lap belt, 3" (76) mm wide
LED working floodlight, rear (2 pieces)	Arm rest, left, for driver's seat

OTHER OPTIONAL EQUIPMENT

Turbo II Prefilter	Central lubrication system (Lincoln)
Further optional equipment available on request	



Yanmar America
 101 International Pkwy
 Adairsville, GA 30103
 770-877-9894
 www.yanmar.com/us

